

▼ Shown from left to right: CLSG-1506, CLSG-2006, CLSG-506



## The Single-Acting Heavy Lifting Solution with Integral Stop Ring

- Integral stop ring provides piston blow-out protection
- Baked enamel outside finish and plated pistons provide superior corrosion protection
- Base mounting holes standard on all models
- Plunger wiper reduces contamination, extending cylinder life
- Single-acting load return



### Saddles

All CLSG-Series cylinders are equipped with bolt-on removable grooved saddles. For information on optional tilt saddles, see selection chart.

Page: 39



### Gauges

Minimize the risk of overloading and ensure long, dependable service from your equipment. Refer to the System Components section for a full range of gauges.

Page: 113



### Optimum Performance

Enerpac's range of Z-Class electric pumps, fitted with manual or solenoid operated 3-way valves, offer optimum combinations with CLSG cylinders.

Page: 76



### Low Height - High Tonnage

When low height with high force is required, CLP-Series Pancake Cylinders with lock nut offer the solution to lift the first few inches.

Page: 20

▼ Eight CLSG-2506 cylinders equipped with tilting saddles lifted the planking of the bridge as the pier heads were being rebuilt.



# Single-Acting, High Tonnage Cylinders

## ▼ QUICK SELECTION CHART

For complete technical information see next page.

Cylinder Capacity (ton) [maximum]	Stroke (in)	Model Number	Cylinder Effective Area (in <sup>2</sup> )	Oil Capacity (in <sup>3</sup> )	Collapsed Height (in)	Weight (lbs)
50 [59.1]	1.97	CLSG-502	11.81	23.25	6.38	37
	3.94	CLSG-504	11.81	46.50	8.35	44
	5.91	CLSG-506	11.81	69.75	10.31	51
	7.87	CLSG-508	11.81	93.00	12.28	60
	9.84	CLSG-5010	11.81	116.25	14.25	68
	11.81	CLSG-5012	11.81	139.50	16.22	75
100 [102.9]	1.97	CLSG-1002	20.57	40.50	7.16	42
	3.94	CLSG-1004	20.57	81.00	9.13	64
	5.91	CLSG-1006	20.57	121.50	11.09	88
	7.87	CLSG-1008	20.57	162.00	13.06	110
	9.84	CLSG-10010	20.57	202.50	15.03	134
	11.81	CLSG-10012	20.57	242.99	17.00	157
150 [153.9]	1.97	CLSG-1502	30.78	60.58	7.72	86
	3.94	CLSG-1504	30.78	121.17	9.69	115
	5.91	CLSG-1506	30.78	181.75	11.65	143
	7.87	CLSG-1508	30.78	242.33	13.62	172
	9.84	CLSG-15010	30.78	302.92	15.59	203
	11.81	CLSG-15012	30.78	363.50	17.56	231
200 [206.1]	1.97	CLSG-2002	41.22	81.13	8.50	121
	5.91	CLSG-2006	41.22	243.40	12.44	201
	11.81	CLSG-20012	41.22	486.79	18.35	322
250 [284.0]	1.97	CLSG-2502	56.80	111.81	9.25	196
	5.91	CLSG-2506	56.80	335.42	13.19	300
	11.81	CLSG-25012	56.80	670.84	19.09	456
300 [353.6]	1.97	CLSG-3002	70.71	139.19	12.28	406
	5.91	CLSG-3006	70.71	417.56	16.22	511
	11.81	CLSG-30012	70.71	835.11	22.13	668
400 [433.9]	1.97	CLSG-4002	86.78	170.84	14.74	595
	5.91	CLSG-4006	86.78	512.51	18.68	728
	11.81	CLSG-40012	86.78	1025.02	24.59	928
500 [566.3]	1.97	CLSG-5002	113.25	222.92	16.50	884
	5.91	CLSG-5006	113.25	668.77	20.43	1058
	11.81	CLSG-50012	113.25	1337.55	26.34	1321
600 [662.9]	1.97	CLSG-6002	132.57	260.97	16.89	1045
	5.91	CLSG-6006	132.57	782.90	20.83	1246
	11.81	CLSG-60012	132.57	1565.81	26.73	1545
800 [911.6]	1.97	CLSG-8002	182.32	358.91	18.66	1634
	5.91	CLSG-8006	182.32	10776.72	22.60	1941
	11.81	CLSG-80012	182.32	2153.44	28.50	2332
1000 [1136]	1.97	CLSG-10002	227.19	447.23	22.20	2341
	5.91	CLSG-10006	227.19	1341.68	26.14	2674
	11.81	CLSG-100012	227.19	2683.35	32.05	3172

## CLSG Series



Capacity:

**50-1,000 tons**

Stroke:

**1.97-11.81 inches**

Maximum Operating Pressure:

**10,000 psi**



### Standard Features

- Interchangeable, hardened grooved saddles
- CR-400 Coupler and dust cap
- Top and side mount lifting eye capability
- All cylinders meet ASME B-30.1 and ISO 10100 Standards



### Additional Stroke Lengths

Models above 150 tons are also available with standard stroke lengths of 4, 8 and 10 inches. Please contact Enerpac for ordering information and dimensional details.



### Lifting an Unbalanced Load

When lifting an unbalanced load **Enerpac Synchronous Lift Systems** can be the solution with multiple lift point capabilities from 4 to 64 points. See our "Yellow Pages" for multi-cylinder set-ups.



### Mounting Hole Orientation

Top mounting hole orientation is maintained to port location. Base mounting hole orientation is not maintained to port location.

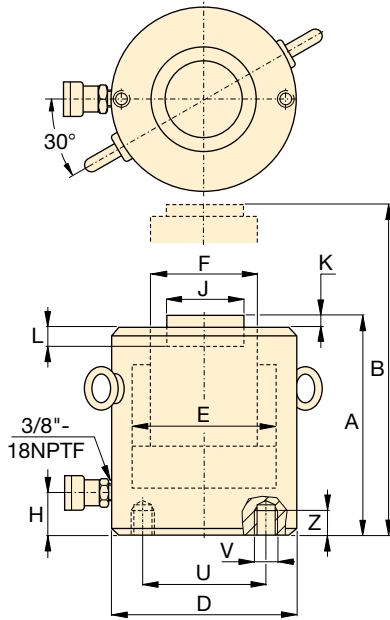

CLSG-50 to CLSG-150 models

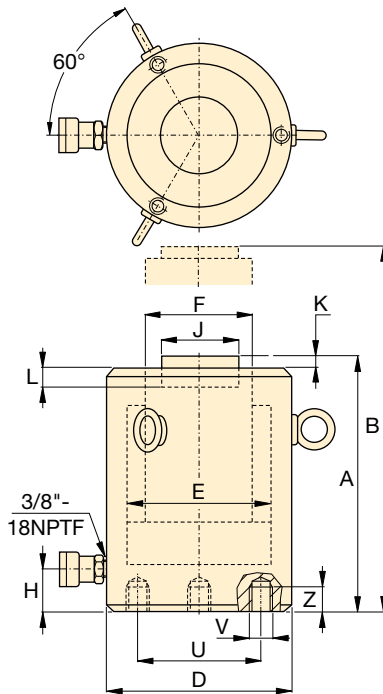

CLSG-200 to CLSG-1000 models

◀ For full features see page 36.

Cylinder Capacity (ton) [maximum]	Stroke (in)	Model Number	Cylinder Effective Area (in <sup>2</sup> )	Oil Capacity (in <sup>3</sup> )	Collapsed Height A (in)	Extended Height B (in)	Outside Diam. D (in)
50 [59.1]	1.97	CLSG-502	11.81	23.25	6.38	8.35	5.12
	3.94	CLSG-504	11.81	46.50	8.35	12.28	5.12
	5.91	CLSG-506	11.81	69.75	10.31	16.22	5.12
	7.87	CLSG-508	11.81	93.00	12.28	20.16	5.12
	9.84	CLSG-5010	11.81	116.25	14.25	24.09	5.12
	11.81	CLSG-5012	11.81	139.50	16.22	28.03	5.12
100 [102.9]	1.97	CLSG-1002	20.57	40.50	7.16	9.13	6.50
	3.94	CLSG-1004	20.57	81.00	9.13	13.06	6.50
	5.91	CLSG-1006	20.57	121.50	11.09	17.00	6.50
	7.87	CLSG-1008	20.57	162.00	13.06	20.94	6.50
	9.84	CLSG-10010	20.57	202.50	15.03	24.87	6.50
	11.81	CLSG-10012	20.57	242.99	17.00	28.81	6.50
150 [153.9]	1.97	CLSG-1502	30.78	60.58	7.72	9.69	8.07
	3.94	CLSG-1504	30.78	121.17	9.69	13.62	8.07
	5.91	CLSG-1506	30.78	181.75	11.65	17.56	8.07
	7.87	CLSG-1508	30.78	242.33	13.62	21.50	8.07
	9.84	CLSG-15010	30.78	302.92	15.59	25.43	8.07
	11.81	CLSG-15012	30.78	363.50	17.56	29.37	8.07
200 [206.1]	1.97	CLSG-2002	41.22	81.13	8.50	10.47	9.25
	5.91	CLSG-2006	41.22	243.40	12.44	18.35	9.25
	11.81	CLSG-20012	41.22	486.79	18.35	30.16	9.25
250 [284.0]	1.97	CLSG-2502	56.80	111.81	9.25	11.22	10.83
	5.91	CLSG-2506	56.80	335.42	13.19	19.09	10.83
	11.81	CLSG-25012	56.80	670.84	19.09	30.91	10.83
300 [353.6]	1.97	CLSG-3002	70.71	139.19	12.28	14.25	12.20
	5.91	CLSG-3006	70.71	417.56	16.22	22.13	12.20
	11.81	CLSG-30012	70.71	835.11	22.13	33.94	12.20
400 [433.9]	1.97	CLSG-4002	86.78	170.84	14.74	16.71	13.78
	5.91	CLSG-4006	86.78	512.51	18.68	24.59	13.78
	11.81	CLSG-40012	86.78	1025.02	24.59	36.40	13.78
500 [566.3]	1.97	CLSG-5002	113.25	222.92	16.50	18.46	15.75
	5.91	CLSG-5006	113.25	668.77	20.43	26.34	15.75
	11.81	CLSG-50012	113.25	1337.55	26.34	38.15	15.75
600 [662.9]	1.97	CLSG-6002	132.57	260.97	16.89	18.86	16.93
	5.91	CLSG-6006	132.57	782.90	20.83	26.73	16.93
	11.81	CLSG-60012	132.57	1565.81	26.73	38.54	16.93
800 [911.6]	1.97	CLSG-8002	182.32	358.91	18.66	20.63	19.88
	5.91	CLSG-8006	182.32	1076.72	22.60	28.50	19.88
	11.81	CLSG-80012	182.32	2153.44	28.50	40.31	19.88
1000 [1136]	1.97	CLSG-10002	227.19	447.23	22.20	24.17	22.05
	5.91	CLSG-10006	227.19	1341.68	26.14	32.05	22.05
	11.81	CLSG-100012	227.19	2683.35	32.05	43.86	22.05

# Single-Acting, High Tonnage Cylinders

## Optional Tilt Saddle \*

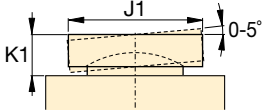

Capacity:  
**50-1,000 tons**

Stroke:  
**1.97-11.81 inches**

Maximum Operating Pressure:  
**10,000 psi**

**CLSG**  
Series



Cylinder Bore Diam.	Plunger Diam.	Base to Advance Port	Standard Saddle Diam.	Saddle Protrusion from Plngr.	Depth of Plunger Hole	Base Mounting Holes			Weight (lbs)	Model Number	* Optional Tilt Saddle		
						Bolt Cir. Diam.	Thread	Thread Depth			Diam.	Height	Model Number
E (in)	F (in)	H (in)	J (in)	K (in)	L (in)	U (in)	V (mm)	Z (in)		J1 (in)	K1 (in)		
3.88	2.76	2.05	1.97	.04	.75	2.56	M12	.87	37	CLSG-502	1.95	.94	CATG-50
3.88	2.76	2.05	1.97	.04	.75	2.56	M12	.87	44	CLSG-504	1.95	.94	CATG-50
3.88	2.76	2.05	1.97	.04	.75	2.56	M12	.87	51	CLSG-506	1.95	.94	CATG-50
3.88	2.76	2.05	1.97	.04	.75	2.56	M12	.87	60	CLSG-508	1.95	.94	CATG-50
3.88	2.76	2.05	1.97	.04	.75	2.56	M12	.87	68	CLSG-5010	1.95	.94	CATG-50
3.88	2.76	2.05	1.97	.04	.75	2.56	M12	.87	75	CLSG-5012	1.95	.94	CATG-50
5.12	3.74	2.13	2.95	.04	.75	3.74	M12	.87	42	CLSG-1002	2.86	1.14	CATG-100
5.12	3.74	2.13	2.95	.04	.75	3.74	M12	.87	64	CLSG-1004	2.86	1.14	CATG-100
5.12	3.74	2.13	2.95	.04	.75	3.74	M12	.87	88	CLSG-1006	2.86	1.14	CATG-100
5.12	3.74	2.13	2.95	.04	.75	3.74	M12	.87	110	CLSG-1008	2.86	1.14	CATG-100
5.12	3.74	2.13	2.95	.04	.75	3.74	M12	.87	134	CLSG-10010	2.86	1.14	CATG-100
5.12	3.74	2.13	2.95	.04	.75	3.74	M12	.87	157	CLSG-10012	2.86	1.14	CATG-100
6.26	4.49	2.40	3.70	.04	.75	5.12	M12	.87	86	CLSG-1502	3.56	1.21	CATG-150
6.26	4.49	2.40	3.70	.04	.75	5.12	M12	.87	115	CLSG-1504	3.56	1.21	CATG-150
6.26	4.49	2.40	3.70	.04	.75	5.12	M12	.87	143	CLSG-1506	3.56	1.21	CATG-150
6.26	4.49	2.40	3.70	.04	.75	5.12	M12	.87	172	CLSG-1508	3.56	1.21	CATG-150
6.26	4.49	2.40	3.70	.04	.75	5.12	M12	.87	203	CLSG-15010	3.56	1.21	CATG-150
6.26	4.49	2.40	3.70	.04	.75	5.12	M12	.87	231	CLSG-15012	3.56	1.21	CATG-150
7.24	5.24	2.62	4.45	.04	.94	6.50	M12	.87	121	CLSG-2002	4.64	1.37	CATG-200
7.24	5.24	2.62	4.45	.04	.94	6.50	M12	.87	201	CLSG-2006	4.64	1.37	CATG-200
7.24	5.24	2.62	4.45	.04	.94	6.50	M12	.87	322	CLSG-20012	4.64	1.37	CATG-200
8.50	6.50	2.87	5.71	.04	.94	7.48	M12	.87	196	CLSG-2502	5.60	1.81	CATG-250
8.50	6.50	2.87	5.71	.04	.94	7.48	M12	.87	300	CLSG-2506	5.60	1.81	CATG-250
8.50	6.50	2.87	5.71	.04	.94	7.48	M12	.87	456	CLSG-25012	5.60	1.81	CATG-250
9.49	7.76	3.98	6.97	.04	.75	7.09	M16	1.42	406	CLSG-3002	6.30	2.42	CATG-300
9.49	7.76	3.98	6.97	.04	.75	7.09	M16	1.42	511	CLSG-3006	6.30	2.42	CATG-300
9.49	7.76	3.98	6.97	.04	.75	7.09	M16	1.42	668	CLSG-30012	6.30	2.42	CATG-300
10.51	8.50	4.49	7.72	.12	1.06	8.07	M16	1.42	595	CLSG-4002	7.59	2.00	CATG-400
10.51	8.50	4.49	7.72	.12	1.06	8.07	M16	1.42	728	CLSG-4006	7.59	2.00	CATG-400
10.51	8.50	4.49	7.72	.12	1.06	8.07	M16	1.42	928	CLSG-40012	7.59	2.00	CATG-400
12.01	9.76	4.49	8.98	.12	1.06	9.84	M24	1.50	884	CLSG-5002	8.98	2.48	CATG-500
12.01	9.76	4.49	8.98	.12	1.06	9.84	M24	1.50	1058	CLSG-5006	8.98	2.48	CATG-500
12.01	9.76	4.49	8.98	.12	1.06	9.84	M24	1.50	1321	CLSG-50012	8.98	2.48	CATG-500
12.99	10.51	4.49	9.72	.12	1.06	10.83	M24	1.50	1045	CLSG-6002	9.47	2.99	CATG-600
12.99	10.51	4.49	9.72	.12	1.06	10.83	M24	1.50	1246	CLSG-6006	9.47	2.99	CATG-600
12.99	10.51	4.49	9.72	.12	1.06	10.83	M24	1.50	1545	CLSG-60012	9.47	2.99	CATG-600
15.24	12.48	5.87	11.69	.12	1.06	12.99	M24	1.50	1634	CLSG-8002	11.28	2.94	CATG-800
15.24	12.48	5.87	11.69	.12	1.06	12.99	M24	1.50	1914	CLSG-8006	11.28	2.94	CATG-800
15.24	12.48	5.87	11.69	.12	1.06	12.99	M24	1.50	2332	CLSG-80012	11.28	2.94	CATG-800
17.01	13.50	6.85	12.72	.12	1.06	14.76	M24	1.50	2341	CLSG-10002	12.35	3.65	CATG-1000
17.01	13.50	6.85	12.72	.12	1.06	14.76	M24	1.50	2674	CLSG-10006	12.35	3.65	CATG-1000
17.01	13.50	6.85	12.72	.12	1.06	14.76	M24	1.50	3172	CLSG-100012	12.35	3.65	CATG-1000



▼ Shown from left to right: CLRG-506, CLRG-2006, CLRG-1506



- Integral stop ring provides piston blow-out protection
- Double-acting for positive retraction
- Baked enamel outside finish and plated pistons provide superior corrosion resistance
- Safety valve in retract side of cylinder helps to prevent damage in case of accidental over-pressurization
- Interchangeable, hardened grooved saddles are standard
- Plunger wiper reduces contamination, extending cylinder life

▼ CLRG-Series cylinders supported and positioned these automobile deck elements.



## Double-Acting Power Lifters



### Saddles

All CLRG cylinders are equipped with bolt-on removable grooved saddles. For information on optional tilt saddles, see selection chart.

Page: 43



### Safety Device

A pilot-operated check valve (**V-42**) can be inserted between cylinder ports.

This valve provides a safety lock on the cylinder under load at any position and remote control for unlocking.

Page: 128



### Optimum Performance

Enerpac's range of Z-Class electric pumps, fitted with manual or solenoid operated 4-way valves, offer optimum combinations with CLRG cylinders.

Page: 76

▼ Replacing adjustment rolls under a fly-over with CLRG cylinders, for controlled lifting and lowering.



# Double-Acting, High Tonnage Cylinders

## ▼ QUICK SELECTION CHART

For complete technical information see next page.

Cylinder Capacity (ton)	Stroke (in)	Model Number	Cylinder Effective Area (in <sup>2</sup> )		Oil Capacity (in <sup>3</sup> )		Collapsed Height (in)
			Push	Pull	Push	Pull	
50	1.97	CLRG-502	11.81	5.85	23.25	11.51	6.38
	3.94	CLRG-504	11.81	5.85	46.50	23.02	8.35
	5.91	CLRG-506	11.81	5.85	69.75	34.52	10.31
	7.87	CLRG-508	11.81	5.85	93.00	46.03	12.28
	9.84	CLRG-5010	11.81	5.85	116.25	57.54	14.25
	11.81	CLRG-5012	11.81	5.85	139.50	69.05	16.22
100	1.97	CLRG-1002	20.57	9.59	40.50	18.87	7.16
	3.94	CLRG-1004	20.57	9.59	81.00	37.74	9.13
	5.91	CLRG-1006	20.57	9.59	121.50	56.61	11.09
	7.87	CLRG-1008	20.57	9.59	162.00	75.49	13.06
	9.84	CLRG-10010	20.57	9.59	202.50	94.36	15.03
	11.81	CLRG-10012	20.57	9.59	242.99	113.23	17.00
150	1.97	CLRG-1502	30.78	14.96	60.58	29.44	7.72
	3.94	CLRG-1504	30.78	14.96	121.17	58.88	9.69
	5.91	CLRG-1506	30.78	14.96	181.75	88.32	11.65
	7.87	CLRG-1508	30.78	14.96	242.33	117.76	13.62
	9.84	CLRG-15010	30.78	14.96	302.92	147.20	15.59
	11.81	CLRG-15012	30.78	14.96	363.50	176.64	17.56
200	1.97	CLRG-2002	41.22	19.68	81.13	38.74	8.50
	5.91	CLRG-2006	41.22	19.68	243.40	116.23	12.44
	11.81	CLRG-20012	41.22	19.68	486.79	232.46	18.35
250	1.97	CLRG-2502	56.80	23.65	111.81	46.56	9.25
	5.91	CLRG-2506	56.80	23.65	335.42	139.69	13.19
	11.81	CLRG-25012	56.80	23.65	670.84	279.39	19.09
300	1.97	CLRG-3002	70.71	23.46	139.19	46.18	12.28
	5.91	CLRG-3006	70.71	23.46	417.56	138.55	16.22
	11.81	CLRG-30012	70.71	23.46	835.11	277.10	22.13
400	1.97	CLRG-4002	86.79	29.99	170.84	59.03	14.74
	5.91	CLRG-4006	86.79	29.99	512.51	177.09	18.68
	11.81	CLRG-40012	86.79	29.99	1,025	354.18	24.59
500	1.97	CLRG-5002	113.25	38.37	222.92	75.54	16.50
	5.91	CLRG-5006	113.25	38.37	668.77	226.61	20.43
	11.81	CLRG-50012	113.25	38.37	1,338	453.22	26.34
600	1.97	CLRG-6002	132.57	45.79	260.97	90.13	16.89
	5.91	CLRG-6006	132.57	45.79	782.90	270.39	20.83
	11.81	CLRG-60012	132.57	45.79	1,566	540.79	26.73
800	1.97	CLRG-8002	182.32	59.99	358.91	118.09	18.66
	5.91	CLRG-8006	182.32	59.99	1,077	354.28	22.60
	11.81	CLRG-80012	182.32	59.99	2,153	708.57	28.50
1000	1.97	CLRG-10002	227.19	83.97	447.23	165.29	22.20
	5.91	CLRG-10006	227.19	83.97	1,342	495.87	26.14
	11.81	CLRG-100012	227.19	83.97	2,683	991.75	32.05

## CLRG Series



Capacity:

**50-1,000 tons**

Stroke:

**1.97-11.81 inches**

Maximum Operating Pressure:

**10,000 psi**



### Standard Features

- Interchangeable, hardened grooved saddles
- CR-400 Coupler and dust cap
- Top and side mount lifting eye capability
- All cylinders meet ASME B-30.1 and ISO 10100 Standards



### Pump Selection

A double-acting cylinder must be powered by a pump with a 4-way valve.

Page: 57



### RR-Series

For higher cycle applications, Enerpac RR cylinders are a good alternative.

Page: 32



### Additional Stroke Lengths

Models above 150 tons are also available with standard stroke lengths of 4, 8 and 10 inches. Please contact Enerpac for ordering information.

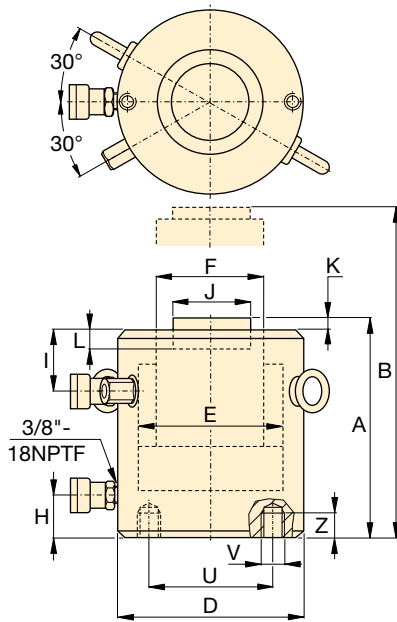

CLRG-50 to CLRG-150 models

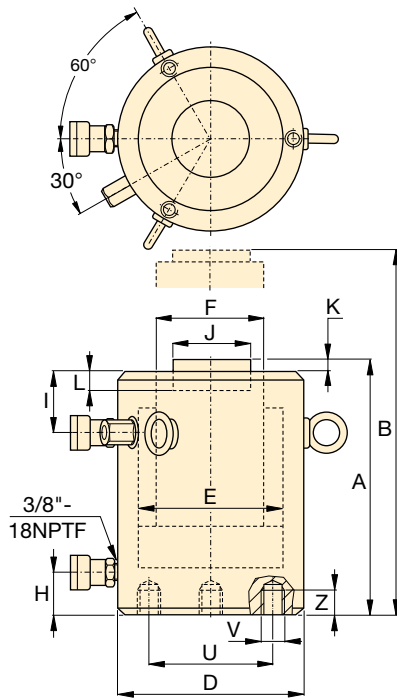

CLRG-200 to CLRG-1000 models



### Mounting Hole Orientation

Top mounting hole orientation is maintained to port location. Base mounting hole orientation is not maintained to port location.

◀ For full features see page 40.

Cylinder Capacity (ton)	Stroke (in)	Model Number	Maximum Cylinder Capacity (ton)		Cylinder Effective Area (in <sup>2</sup> )		Oil Capacity (in <sup>3</sup> )	
			Push	Pull	Push	Pull	Push	Pull
50	1.97	CLRG-502	59.1	29	11.81	5.85	23.25	11.51
	3.94	CLRG-504	59.1	29	11.81	5.85	46.50	23.02
	5.91	CLRG-506	59.1	29	11.81	5.85	69.75	34.52
	7.87	CLRG-508	59.1	29	11.81	5.85	93.00	46.03
	9.84	CLRG-5010	59.1	29	11.81	5.85	116.25	57.54
	11.81	CLRG-5012	59.1	29	11.81	5.85	139.50	69.05
100	1.97	CLRG-1002	102.9	48	20.57	9.59	40.50	18.87
	3.94	CLRG-1004	102.9	48	20.57	9.59	81.00	37.74
	5.91	CLRG-1006	102.9	48	20.57	9.59	121.50	56.61
	7.87	CLRG-1008	102.9	48	20.57	9.59	162.00	75.49
	9.84	CLRG-10010	102.9	48	20.57	9.59	202.50	94.36
	11.81	CLRG-10012	102.9	48	20.57	9.59	242.99	113.23
150	1.97	CLRG-1502	153.9	75	30.78	14.96	60.58	29.44
	3.94	CLRG-1504	153.9	75	30.78	14.96	121.17	58.88
	5.91	CLRG-1506	153.9	75	30.78	14.96	181.75	88.32
	7.87	CLRG-1508	153.9	75	30.78	14.96	242.33	117.76
	9.84	CLRG-15010	153.9	75	30.78	14.96	302.92	147.20
	11.81	CLRG-15012	153.9	75	30.78	14.96	363.50	176.64
200	1.97	CLRG-2002	206.1	98	41.22	19.68	81.13	38.74
	5.91	CLRG-2006	206.1	98	41.22	19.68	243.40	116.23
	11.81	CLRG-20012	206.1	98	41.22	19.68	486.79	232.46
250	1.97	CLRG-2502	284.0	118	56.80	23.65	111.81	46.56
	5.91	CLRG-2506	284.0	118	56.80	23.65	335.42	139.69
	11.81	CLRG-25012	284.0	118	56.80	23.65	670.84	279.39
300	1.97	CLRG-3002	353.6	117	70.71	23.46	139.19	46.18
	5.91	CLRG-3006	353.6	117	70.71	23.46	417.56	138.55
	11.81	CLRG-30012	353.6	117	70.71	23.46	835.11	277.10
400	1.97	CLRG-4002	433.9	150	86.79	29.99	170.84	59.03
	5.91	CLRG-4006	433.9	150	86.79	29.99	512.51	177.09
	11.81	CLRG-40012	433.9	150	86.79	29.99	1,025	354.18
500	1.97	CLRG-5002	566.3	192	113.25	38.37	222.92	75.54
	5.91	CLRG-5006	566.3	192	113.25	38.37	668.77	226.61
	11.81	CLRG-50012	566.3	192	113.25	38.37	1,338	453.22
600	1.97	CLRG-6002	662.9	229	132.57	45.79	260.97	90.13
	5.91	CLRG-6006	662.9	229	132.57	45.79	782.90	270.39
800	1.97	CLRG-8002	911.6	300	182.32	59.99	358.91	118.09
	5.91	CLRG-8006	911.6	300	182.32	59.99	1,077	354.28
1000	1.97	CLRG-10002	1136	420	227.19	83.97	447.23	165.29
	5.91	CLRG-10006	1136	420	227.19	83.97	1,342	495.87
	11.81	CLRG-100012	1136	420	227.19	83.97	2,683	991.75

Base Mounting Hole Dimensions (in)			
Model / Capacity ton	Bolt Circle U	Thread Size V (mm)	Minimum Thread Depth Z
CLRG-50	2.56	M12	.87
CLRG-100	3.74	M12	.87
CLRG-150	5.12	M12	.87
CLRG-200	6.50	M12	.87
CLRG-250	7.48	M12	.87
CLRG-300	7.09	M16	1.42
CLRG-400	8.07	M16	1.42
CLRG-500	9.84	M24	1.50
CLRG-600	10.83	M24	1.50
CLRG-800	12.99	M24	1.50
CLRG-1000	14.76	M24	1.50

# Double-Acting, High Tonnage Cylinders

\* Optional Tilt Saddle

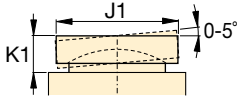

Capacity:

**50-1,000 tons**

Stroke:

**1.97-11.81 inches**

Maximum Operating Pressure:

**10,000 psi**

**CLRG**  
Series



Collap. Height	Ext. Height	Outside Diam.	Cyl. Bore Diam.	Plunger Diam.	Base to Advance Port	Top to Retract Port	Standard Saddle Diam.	Saddle Protrusion from Plngr.	Depth of Plunger Hole	Weight	Model Number	*Optional Tilt Saddle		
												Diam.	Height	Model Number
A (in)	B (in)	D (in)	E (in)	F (in)	H (in)	I (in)	J (in)	K (in)	L (in)	(lbs)		J1 (in)	K1 (in)	
6.38	8.35	5.12	3.88	2.76	1.65	1.29	1.97	.04	.75	37	CLRG-502	1.95	.94	CATG-50
8.35	12.28	5.12	3.88	2.76	1.65	1.29	1.97	.04	.75	44	CLRG-504	1.95	.94	CATG-50
10.31	16.22	5.12	3.88	2.76	1.65	1.29	1.97	.04	.75	51	CLRG-506	1.95	.94	CATG-50
12.28	20.16	5.12	3.88	2.76	1.65	1.29	1.97	.04	.75	60	CLRG-508	1.95	.94	CATG-50
14.25	24.09	5.12	3.88	2.76	1.65	1.29	1.97	.04	.75	68	CLRG-5010	1.95	.94	CATG-50
16.22	28.03	5.12	3.88	2.76	1.65	1.29	1.97	.04	.75	75	CLRG-5012	1.95	.94	CATG-50
7.16	9.13	6.50	5.12	3.74	2.13	1.89	2.95	.04	.75	42	CLRG-1002	2.86	1.14	CATG-100
9.13	13.06	6.50	5.12	3.74	2.13	1.89	2.95	.04	.75	64	CLRG-1004	2.86	1.14	CATG-100
11.09	17.00	6.50	5.12	3.74	2.13	1.89	2.95	.04	.75	88	CLRG-1006	2.86	1.14	CATG-100
13.06	20.94	6.50	5.12	3.74	2.13	1.89	2.95	.04	.75	110	CLRG-1008	2.86	1.14	CATG-100
15.03	24.87	6.50	5.12	3.74	2.13	1.89	2.95	.04	.75	134	CLRG-10010	2.86	1.14	CATG-100
17.00	28.81	6.50	5.12	3.74	2.13	1.89	2.95	.04	.75	157	CLRG-10012	2.86	1.14	CATG-100
7.72	9.69	8.07	6.26	4.49	2.40	2.22	3.70	.04	.75	86	CLRG-1502	3.56	1.21	CATG-150
9.69	13.62	8.07	6.26	4.49	2.40	2.22	3.70	.04	.75	115	CLRG-1504	3.56	1.21	CATG-150
11.65	17.56	8.07	6.26	4.49	2.40	2.22	3.70	.04	.75	143	CLRG-1506	3.56	1.21	CATG-150
13.62	21.50	8.07	6.26	4.49	2.40	2.22	3.70	.04	.75	172	CLRG-1508	3.56	1.21	CATG-150
15.59	25.43	8.07	6.26	4.49	2.40	2.22	3.70	.04	.75	203	CLRG-15010	3.56	1.21	CATG-150
17.56	29.37	8.07	6.26	4.49	2.40	2.22	3.70	.04	.75	231	CLRG-15012	3.56	1.21	CATG-150
8.50	10.47	9.25	7.24	5.24	2.62	2.22	4.45	.04	.94	121	CLRG-2002	4.64	1.37	CATG-200
12.44	18.35	9.25	7.24	5.24	2.62	2.22	4.45	.04	.94	201	CLRG-2006	4.64	1.37	CATG-200
18.35	30.16	9.25	7.24	5.24	2.62	2.22	4.45	.04	.94	322	CLRG-20012	4.64	1.37	CATG-200
9.25	11.22	10.83	8.50	6.50	2.87	3.07	5.71	.04	.94	196	CLRG-2502	5.60	1.81	CATG-250
13.19	19.09	10.83	8.50	6.50	2.87	3.07	5.71	.04	.94	300	CLRG-2506	5.60	1.81	CATG-250
19.09	30.91	10.83	8.50	6.50	2.87	3.07	5.71	.04	.94	456	CLRG-25012	5.60	1.81	CATG-250
12.28	14.25	12.20	9.49	7.76	3.98	2.95	6.97	.04	.75	406	CLRG-3002	6.30	2.42	CATG-300
16.22	22.13	12.20	9.49	7.76	3.98	2.95	6.97	.04	.75	511	CLRG-3006	6.30	2.42	CATG-300
22.13	33.94	12.20	9.49	7.76	3.98	2.95	6.97	.04	.75	668	CLRG-30012	6.30	2.42	CATG-300
14.74	16.71	13.78	10.51	8.50	4.49	4.13	7.72	.12	1.06	595	CLRG-4002	7.59	2.00	CATG-400
18.68	24.59	13.78	10.51	8.50	4.49	4.13	7.72	.12	1.06	728	CLRG-4006	7.59	2.00	CATG-400
24.59	36.40	13.78	10.51	8.50	4.49	4.13	7.72	.12	1.06	928	CLRG-40012	7.59	2.00	CATG-400
16.50	18.46	15.75	12.01	9.76	4.49	5.31	8.98	.12	1.06	884	CLRG-5002	8.98	2.48	CATG-500
20.43	26.34	15.75	12.01	9.76	4.49	5.31	8.98	.12	1.06	1058	CLRG-5006	8.98	2.48	CATG-500
26.34	38.15	15.75	12.01	9.76	4.49	5.31	8.98	.12	1.06	1321	CLRG-50012	8.98	2.48	CATG-500
16.89	18.86	16.93	12.99	10.51	4.49	5.31	9.72	.12	1.06	1045	CLRG-6002	9.47	2.99	CATG-600
20.83	26.73	16.93	12.99	10.51	4.49	5.31	9.72	.12	1.06	1246	CLRG-6006	9.47	2.99	CATG-600
26.73	38.54	16.93	12.99	10.51	4.49	5.31	9.72	.12	1.06	1545	CLRG-60012	9.47	2.99	CATG-600
18.66	20.63	19.88	15.24	12.48	5.87	5.31	11.69	.12	1.06	1634	CLRG-8002	11.28	2.94	CATG-800
22.60	28.50	19.88	15.24	12.48	5.87	5.31	11.69	.12	1.06	1914	CLRG-8006	11.28	2.94	CATG-800
28.50	40.31	19.88	15.24	12.48	5.87	5.31	11.69	.12	1.06	2332	CLRG-80012	11.28	2.94	CATG-800
22.20	24.17	22.05	17.01	13.50	6.85	6.69	12.72	.12	1.06	2341	CLRG-10002	12.35	3.65	CATG-1000
26.14	32.05	22.05	17.01	13.50	6.85	6.69	12.72	.12	1.06	2674	CLRG-10006	12.35	3.65	CATG-1000
32.05	43.86	22.05	17.01	13.50	6.85	6.69	12.72	.12	1.06	3172	CLRG-100012	12.35	3.65	CATG-1000



▼ Shown from left to right: CLL-1006, CLL-2506, CLL-1506, CLL-506



- Safety Lock Nut for mechanical load holding
- Baked enamel outside finish and plated pistons provide superior corrosion resistance
- Overflow port functions as a stroke limiter
- Interchangeable, hardened grooved saddles are standard
- CR-400 coupler and dust cap included on all models
- Single-acting load return

▼ For this curved bridge, CLL-Series cylinders were used to support the concrete beams to level the pierhead and to place 4000 ton slide bearings between pier and pierhead.



## To Secure Loads Mechanically



### Saddles

All CLL cylinders are equipped with bolt-on removable grooved saddles. For information on optional tilt saddles, see the selection chart.

Page: 47



### Gauges

Minimize the risk of overloading and ensure long, dependable service from your equipment. Refer to the System Components section for a full range of gauges.

Page: 113



### Low Height - High Tonnage

When low height with high force is required, pancake cylinders with lock nut offer the solution to lift the first few inches.

Page: 20

▼ CLL cylinder, mechanically locked, after positioning the curved bridge.



# Single-Acting, Lock Nut Cylinders

## ▼ QUICK SELECTION CHART

For complete technical information see next page.

Cylinder Capacity (ton) [maximum]	Stroke (in)	Model Number	Cylinder Effective Area (in <sup>2</sup> )	Oil Capacity (in <sup>3</sup> )	Collapsed Height (in)	Weight (lbs)
<b>50</b> [59.1]	1.97	CLL-502	10.99	21.63	6.46	35
	3.94	CLL-504	10.99	43.25	8.43	46
	5.91	CLL-506	10.99	64.88	10.39	57
	7.87	CLL-508	10.99	86.51	12.36	68
	9.84	CLL-5010	10.99	108.14	14.33	79
	11.81	CLL-5012	10.99	129.76	16.30	90
<b>100</b> [102.9]	1.97	CLL-1002	20.57	40.50	7.36	68
	3.94	CLL-1004	20.57	81.00	9.33	87
	5.91	CLL-1006	20.57	121.50	11.30	106
	7.87	CLL-1008	20.57	162.00	13.27	125
	9.84	CLL-10010	20.57	202.50	15.24	143
	11.81	CLL-10012	20.57	242.99	17.20	162
<b>150</b> [153.9]	1.97	CLL-1502	30.78	60.58	8.23	117
	3.94	CLL-1504	30.78	121.17	10.20	146
	5.91	CLL-1506	30.78	181.75	12.17	174
	7.87	CLL-1508	30.78	242.33	14.13	203
	9.84	CLL-15010	30.78	302.92	16.10	231
	11.81	CLL-15012	30.78	363.50	18.07	260
<b>200</b> [206.1]	1.97	CLL-2002	41.17	81.04	9.57	183
	5.91	CLL-2006	41.17	243.13	13.50	260
	11.81	CLL-20012	41.17	486.27	19.41	376
<b>250</b> [284.0]	1.97	CLL-2502	56.75	111.70	9.80	256
	5.91	CLL-2506	56.75	335.11	13.74	359
	11.81	CLL-25012	56.75	670.22	19.65	515
<b>300</b> [353.6]	1.97	CLL-3002	70.71	139.19	11.61	382
	5.91	CLL-3006	70.71	417.56	15.55	514
	11.81	CLL-30012	70.71	835.11	21.46	712
<b>400</b> [433.9]	1.97	CLL-4002	86.79	170.84	13.19	553
	5.91	CLL-4006	86.79	512.51	17.13	721
	11.81	CLL-40012	86.79	1025.02	23.03	972
<b>500</b> [566.3]	1.97	CLL-5002	113.25	222.99	14.76	809
	5.91	CLL-5006	113.25	668.77	18.70	1029
	11.81	CLL-50012	113.25	1337.55	24.61	1360
<b>600</b> [662.9]	1.97	CLL-6002	132.57	260.97	15.55	985
	5.91	CLL-6006	132.57	782.90	19.49	1241
	11.81	CLL-60012	132.57	1565.81	25.39	1625
<b>800</b> [911.6]	1.97	CLL-8002	182.42	359.09	17.91	1565
	5.91	CLL-8006	182.42	1077.27	21.85	1918
	11.81	CLL-80012	182.42	2154.55	27.76	2446
<b>1000</b> [1136]	1.97	CLL-10002	227.30	447.43	19.49	2094
	5.91	CLL-10006	227.30	1342.30	23.43	2517
	11.81	CLL-100012	227.30	2684.59	29.33	3151

## CLL Series



Capacity:

**50-1,000 tons**

Stroke:

**1.97-11.81 inches**

Maximum Operating Pressure:

**10,000 psi**

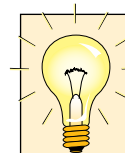

### Additional Stroke Lengths

Models above 150 tons are also available with standard stroke lengths of 4, 8 and 10 inches. Please contact

Enerpac for ordering information and dimensional details.



### Lifting an Unbalanced Load?

See our "Yellow Pages" for multi-cylinder set ups.

Page: **242**



### Speed Chart

See the Enerpac Cylinder Speed Chart in our "Yellow Pages" section.

Page: **251**

# CLL-Series, Lock Nut Cylinders

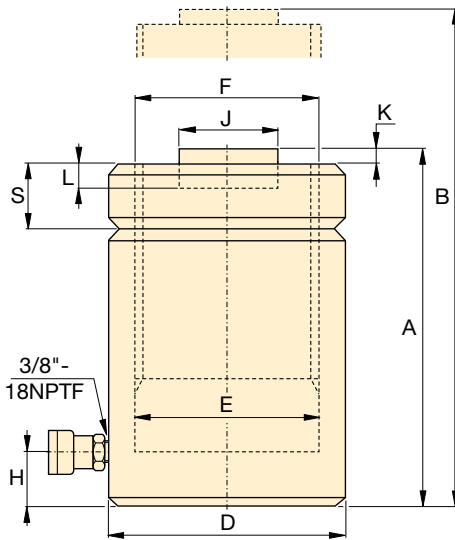
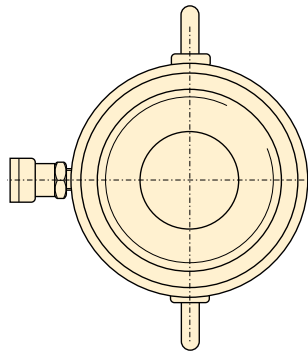

CLL-50 to CLL-250 models

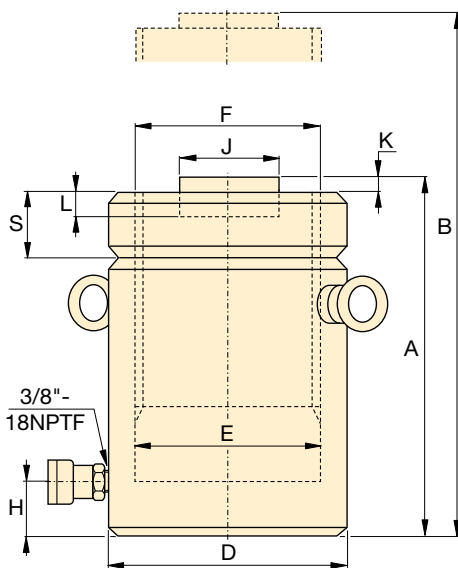
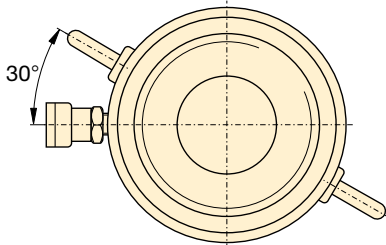

CLL-300 to CLL-1000 models

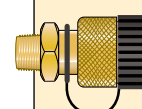

**Coupler Included!**

CR-400 coupler included on all models.  
Fits all HC-Series hoses.

◀ For full features see page 44.

Cylinder Capacity (ton) [maximum]	Stroke (in)	Model Number	Cylinder Effective Area (in <sup>2</sup> )	Oil Capacity (in <sup>3</sup> )
50 [59.1]	1.97	CLL-502	10.99	21.63
	3.94	CLL-504	10.99	43.25
	5.91	CLL-506	10.99	64.88
	7.87	CLL-508	10.99	86.51
	9.84	CLL-5010	10.99	108.14
	11.81	CLL-5012	10.99	129.76
100 [102.9]	1.97	CLL-1002	20.57	40.50
	3.94	CLL-1004	20.57	81.00
	5.91	CLL-1006	20.57	121.50
	7.87	CLL-1008	20.57	162.00
	9.84	CLL-10010	20.57	202.50
	11.81	CLL-10012	20.57	242.99
150 [153.9]	1.97	CLL-1502	30.78	60.58
	3.94	CLL-1504	30.78	121.17
	5.91	CLL-1506	30.78	181.75
	7.87	CLL-1508	30.78	242.33
	9.84	CLL-15010	30.78	302.92
	11.81	CLL-15012	30.78	363.50
200 [206.1]	1.97	CLL-2002	41.17	81.04
	5.91	CLL-2006	41.17	243.13
	11.81	CLL-20012	41.17	486.27
250 [284.0]	1.97	CLL-2502	56.75	111.70
	5.91	CLL-2506	56.75	335.11
	11.81	CLL-25012	56.75	670.22
300 [353.6]	1.97	CLL-3002	70.71	139.19
	5.91	CLL-3006	70.71	417.56
	11.81	CLL-30012	70.71	835.11
400 [433.9]	1.97	CLL-4002	86.79	170.84
	5.91	CLL-4006	86.79	512.51
	11.81	CLL-40012	86.79	1025.02
500 [566.3]	1.97	CLL-5002	113.25	222.99
	5.91	CLL-5006	113.25	668.77
	11.81	CLL-50012	113.25	1337.55
600 [662.9]	1.97	CLL-6002	132.57	260.97
	5.91	CLL-6006	132.57	782.90
	11.81	CLL-60012	132.57	1565.81
800 [911.6]	1.97	CLL-8002	182.42	359.09
	5.91	CLL-8006	182.42	1077.27
	11.81	CLL-80012	182.42	2154.55
1000 [1136]	1.97	CLL-10002	227.30	447.43
	5.91	CLL-10006	227.30	1342.30
	11.81	CLL-100012	227.30	2684.59

# Single-Acting, Lock Nut Cylinders

## \*Optional Tilt Saddle

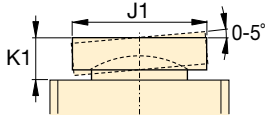

Capacity:  
**50-1,000 tons**

Stroke:  
**1.97-11.81 inches**

Maximum Operating Pressure:  
**10,000 psi**

**CLL**  
Series



Collap. Height	Ext. Height	Outside Diam.	Cyl. Bore Diam.	Plunger Diameter (threaded)	Base to Advance Port	Stand. Saddle Diam.	Saddle Protrusion from Plgr.	Depth of Plunger Hole	Lock Nut Height	Weight	Model Number	* Optional Tilt Saddle		
												Diam.	Height	Model Number
A (in)	B (in)	D (in)	E (in)	F (mm)	H (in)	J (in)	K (in)	L (in)	S (in)	(lbs)		J1 (in)	K1 (in)	
6.46	8.43	4.92	3.74	Tr 95 x 4	1.18	2.80	.08	.51	1.42	35	CLL-502	2.80	.94	CAT-100
8.43	12.36	4.92	3.74	Tr 95 x 4	1.18	2.80	.08	.51	1.42	46	CLL-504	2.80	.94	CAT-100
10.39	16.30	4.92	3.74	Tr 95 x 4	1.18	2.80	.08	.51	1.42	57	CLL-506	2.80	.94	CAT-100
12.36	20.24	4.92	3.74	Tr 95 x 4	1.18	2.80	.08	.51	1.42	68	CLL-508	2.80	.94	CAT-100
14.33	24.17	4.92	3.74	Tr 95 x 4	1.18	2.80	.08	.51	1.42	79	CLL-5010	2.80	.94	CAT-100
16.30	28.11	4.92	3.74	Tr 95 x 4	1.18	2.80	.08	.51	1.42	90	CLL-5012	2.80	.94	CAT-100
7.36	9.33	6.50	5.12	Tr 130 x 6	1.18	2.80	.08	.51	1.73	68	CLL-1002	2.80	.94	CAT-100
9.33	13.27	6.50	5.12	Tr 130 x 6	1.18	2.80	.08	.51	1.73	87	CLL-1004	2.80	.94	CAT-100
11.30	17.20	6.50	5.12	Tr 130 x 6	1.18	2.80	.08	.51	1.73	106	CLL-1006	2.80	.94	CAT-100
13.27	21.14	6.50	5.12	Tr 130 x 6	1.18	2.80	.08	.51	1.73	125	CLL-1008	2.80	.94	CAT-100
15.24	25.08	6.50	5.12	Tr 130 x 6	1.18	2.80	.08	.51	1.73	143	CLL-10010	2.80	.94	CAT-100
17.20	29.02	6.50	5.12	Tr 130 x 6	1.18	2.80	.08	.51	1.73	162	CLL-10012	2.80	.94	CAT-100
8.23	10.20	8.07	6.26	Tr 159 x 6	1.54	5.12	.08	.98	1.73	117	CLL-1502	5.12	.79	CAT-200
10.20	14.13	8.07	6.26	Tr 159 x 6	1.54	5.12	.08	.98	1.73	146	CLL-1504	5.12	.79	CAT-200
12.17	18.07	8.07	6.26	Tr 159 x 6	1.54	5.12	.08	.98	1.73	174	CLL-1506	5.12	.79	CAT-200
14.13	22.01	8.07	6.26	Tr 159 x 6	1.54	5.12	.08	.98	1.73	203	CLL-1508	5.12	.79	CAT-200
16.10	25.94	8.07	6.26	Tr 159 x 6	1.54	5.12	.08	.98	1.73	231	CLL-15010	5.12	.79	CAT-200
18.07	29.88	8.07	6.26	Tr 159 x 6	1.54	5.12	.08	.98	1.73	260	CLL-15012	5.12	.79	CAT-200
9.57	11.54	9.25	7.24	Tr 184 x 6	1.97	5.12	.08	.98	1.97	183	CLL-2002	5.12	.79	CAT-200
13.50	19.41	9.25	7.24	Tr 184 x 6	1.97	5.12	.08	.98	1.97	260	CLL-2006	5.12	.79	CAT-200
19.41	31.22	9.25	7.24	Tr 184 x 6	1.97	5.12	.08	.98	1.97	376	CLL-20012	5.12	.79	CAT-200
9.80	11.77	10.83	8.50	Tr 216 x 6	1.97	5.91	.08	.98	2.20	256	CLL-2502	5.91	.83	CAT-250
13.74	19.65	10.83	8.50	Tr 216 x 6	1.97	5.91	.08	.98	2.20	359	CLL-2506	5.91	.83	CAT-250
19.65	31.46	10.83	8.50	Tr 216 x 6	1.97	5.91	.08	.98	2.20	515	CLL-25012	5.91	.83	CAT-250
11.61	13.58	12.20	9.49	Tr 241 x 6	2.32	5.47	.20	.98	2.36	382	CLL-3002	7.68	2.95	CAT-300
15.55	21.46	12.20	9.49	Tr 241 x 6	2.32	5.47	.20	.98	2.36	514	CLL-3006	7.68	2.95	CAT-300
21.46	33.27	12.20	9.49	Tr 241 x 6	2.32	5.47	.20	.98	2.36	712	CLL-30012	7.68	2.95	CAT-300
13.19	15.16	13.78	10.51	Tr 266 x 6	2.76	6.26	.20	.98	2.76	553	CLL-4002	8.86	3.35	CAT-400
17.13	23.03	13.78	10.51	Tr 266 x 6	2.76	6.26	.20	.98	2.76	721	CLL-4006	8.86	3.35	CAT-400
23.03	34.84	13.78	10.51	Tr 266 x 6	2.76	6.26	.20	.98	2.76	972	CLL-40012	8.86	3.35	CAT-400
14.76	16.73	15.75	12.01	Tr 305 x 6	3.15	7.05	.20	.98	3.15	809	CLL-5002	9.84	3.58	CAT-500
18.70	24.61	15.75	12.01	Tr 305 x 6	3.15	7.05	.20	.98	3.15	1029	CLL-5006	9.84	3.58	CAT-500
24.61	36.42	15.75	12.01	Tr 305 x 6	3.15	7.05	.20	.98	3.15	1360	CLL-50012	9.84	3.58	CAT-500
15.55	17.52	16.93	12.99	Tr 330 x 6	3.35	7.64	.20	.98	3.35	985	CLL-6002	10.83	3.78	CAT-600
19.49	25.39	16.93	12.99	Tr 330 x 6	3.35	7.64	.20	.98	3.35	1241	CLL-6006	10.83	3.78	CAT-600
25.39	37.20	16.93	12.99	Tr 330 x 6	3.35	7.64	.20	.98	3.35	1625	CLL-60012	10.83	3.78	CAT-600
17.91	19.88	19.88	15.24	Tr 387 x 6	3.94	8.82	.20	.98	3.94	1565	CLL-8002	12.60	4.84	CAT-800
21.85	27.76	19.88	15.24	Tr 387 x 6	3.94	8.82	.20	.98	3.94	1918	CLL-8006	12.60	4.84	CAT-800
27.76	39.57	19.88	15.24	Tr 387 x 6	3.94	8.82	.20	.98	3.94	2446	CLL-80012	12.60	4.84	CAT-800
19.49	21.46	22.05	17.01	Tr 432 x 6	4.33	9.80	.20	.98	4.33	2094	CLL-10002	14.17	5.35	CAT-1000
23.43	29.33	22.05	17.01	Tr 432 x 6	4.33	9.80	.20	.98	4.33	2517	CLL-10006	14.17	5.35	CAT-1000
29.33	41.14	22.05	17.01	Tr 432 x 6	4.33	9.80	.20	.98	4.33	3151	CLL-100012	14.17	5.35	CAT-1000